

RLS-1000B Remote Link Switch

RLS-1000B Remote Base Switch

The RLS-1000B provides a method to connect up to three transceivers to the remote base port of the CAT-1000B, CAT-700B, CAT-300DXL, CAT-250 or CAT-200B repeater controllers or two transceiver to the CAT-300 controller. Transceiver selection is accomplished by grounding three control lines. Since the receiver audio and COR inputs are mixed, all three transceivers can be selected at the same time. To select a transceiver, connect the CAT-1000B user function switch outputs to the control line inputs on the RLS-1000B.

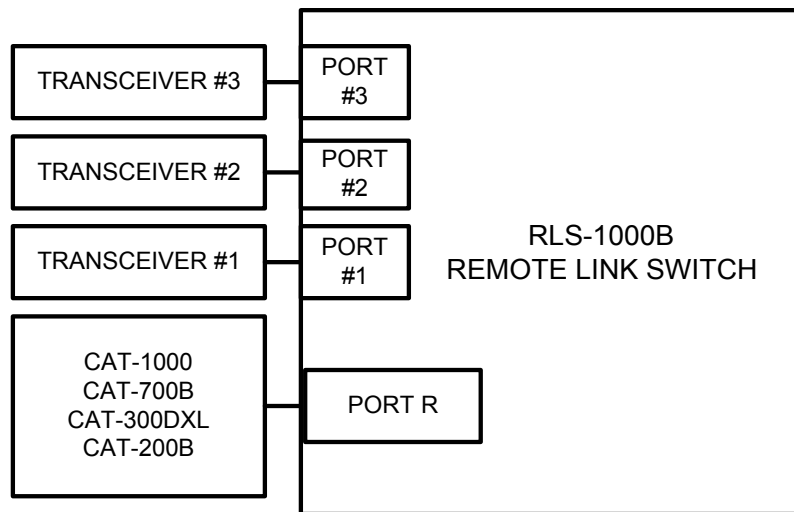

Figure 1

COR Output Polarity

The Repeater COR output (J4-18) will always be active HIGH. The COR polarity dipswitch on the CAT-1000 must be set to the OFF position.

Audio Input Output

The audio input and output circuits are identical to the CAT Controllers. Level adjustments on both the input and output amplifiers make it easy to compensate for varying input and output requirements. The audio input impedance is 10K ohms while the output impedance is 600 ohms.

Receiver Audio Response

Each receiver input has a buffer amplifier with a gain of three. The frequency response is flat over a range of 300 to 3000 Hz. If discriminator audio is being used, it may be necessary to add some high frequency roll off. Space has been provided to install a capacitor across the feedback resistor on each receive audio amplifier. These locations are identified on the RLS-1000B board as C2, C11 and C16. Start with a .0047uF capacitor. Increase the value to provide more high frequency roll off or decrease the value to provide less high frequency roll off.

Dip Switch Selection

Switch #1 - Port #1 COR Polarity

This switch determines COR input logic for the RLS-1000B port #1 input. Switch #1 should be OFF if the COR input is active high and ON if the COR input is active low. For an active low COR input a pull-up resistor may be required. Install a 2200 ohm .25W resistor on the RLS-1000B board at the R33 position.

Switch #2 - Port #2 COR Polarity

This switch determines COR input logic for the RLS-1000B port #2 input. Switch #2 should be OFF if the COR input is active high and ON if the COR input is active low. For an active low COR input a pull-up resistor may be required. Install a 2200 ohm .25W resistor on the RLS-1000B board at the R34 position.

Switch #3 - Port #3 COR Polarity

This switch determines COR input logic for the RLS-1000B port #3 input. Switch #3 should be ON if the COR input is active high and OFF if the COR input is active low. For an active low COR input a pull-up resistor may be required. Install a 2200 ohm .25W resistor on the RLS-1000B board at the R35 position.

Switch #4 - Port #1 Configuration

This switch configures port #1. If a transceiver is connected to the RLS-1000B at port #1, dipswitch #4 should be in the OFF position. If a repeater is connected to port #1, dipswitch #4 should be in the ON position.

Switch #5 - Port #2 Configuration

This switch configures port #2. If a transceiver is connected to the RLS-1000B at port #2, dipswitch #5 should be in the OFF position. If a repeater is connected to port #2, dipswitch #5 should be in the ON position.

Switch #6 - Port #3 Configuration

This switch configures port #3. If a transceiver is connected to the RLS-1000B at port #3, dipswitch #6 should be in the OFF position. If a repeater is connected to port #3, dipswitch #6 should be in the ON position.

Switch #7 - Port #1 Priority Enable

Switch #7 provides a method of assigning port #1 with priority over ports #2 and #3. If switch #7 is OFF the RLS-1000B will be configured for normal operation. Any COR input will enable the corresponding audio switch and pass the receive audio to the mixer. If switch #7 is ON port #1 will have priority. Audio switches for ports #2 and #3 will be disabled when port #1 COR is active.

Switch #8 - Port #1 CAT-300 Mode Enable

This switch configures the RLS-1000B for operation with the CAT-300 controller in the one repeater, two-transceiver mode.

CAT-1000 - RLS-1000B Interconnect

Figure 2 describes how to connect three remote base transceivers to the link port of the CAT-1000B controller. Use the CAT-1000B user function switches one, two and three to control the RBS-1000B Remote Base Switch.

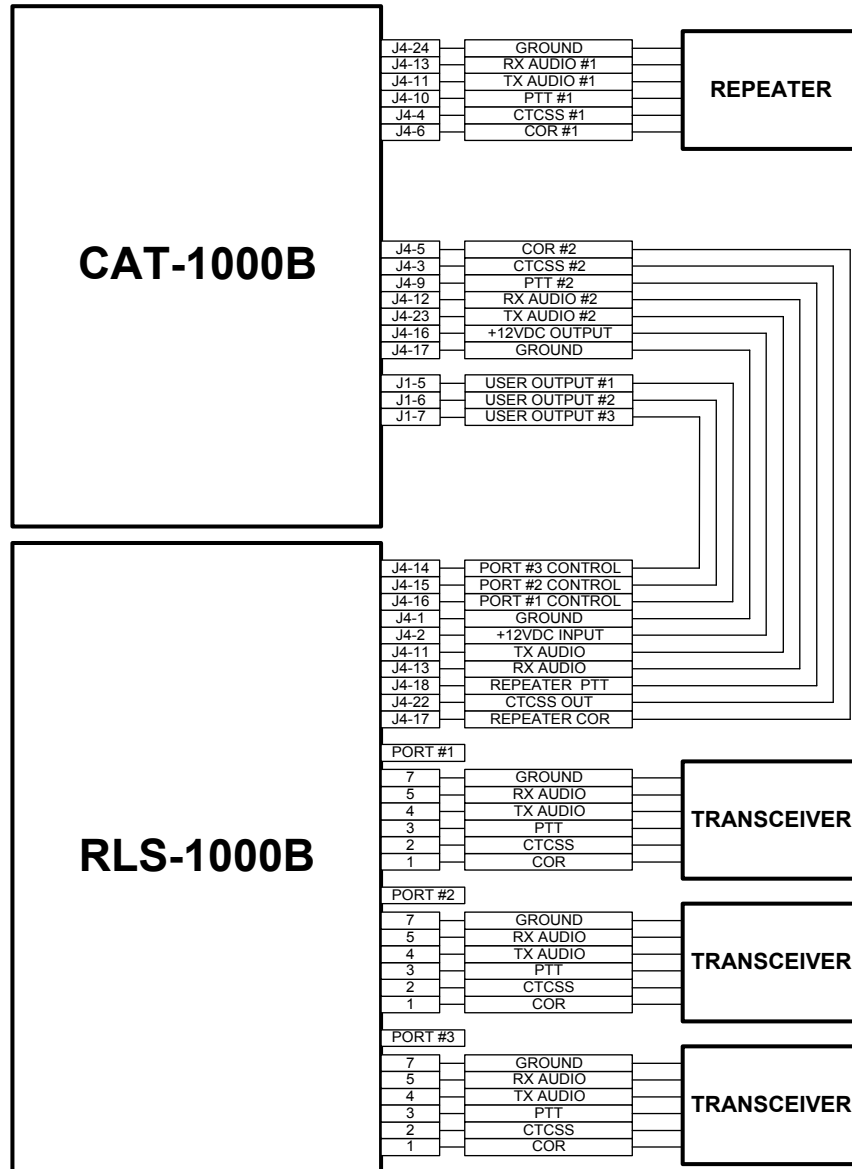

Figure 2

CAT-200B - RLS-1000B Interconnect

Figure 3 describes how to connect three remote base transceivers to the link port of the CAT-200B controller. Use the CAT-200B user function switches one, two and three to control the RBS-1000B Remote Base Switch.

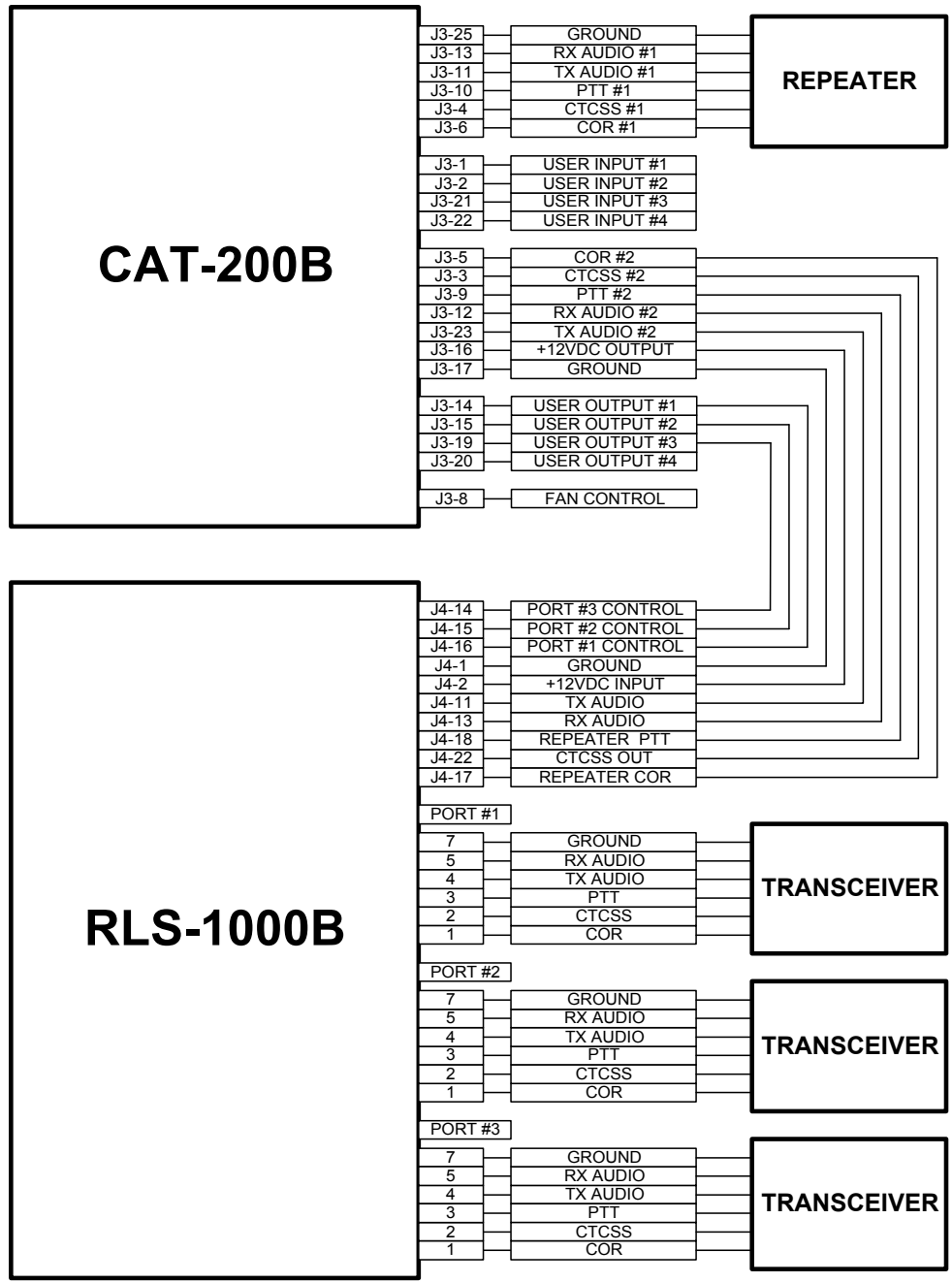

Figure 3

CAT-300DXL - RLS-1000B Interconnect

Figure 4 describes how to connect three remote base transceivers to the link port of the CAT-300DXL controller. Use the CAT-300DXL user function switches one, two and three to control the RBS-1000B Remote Base Switch.

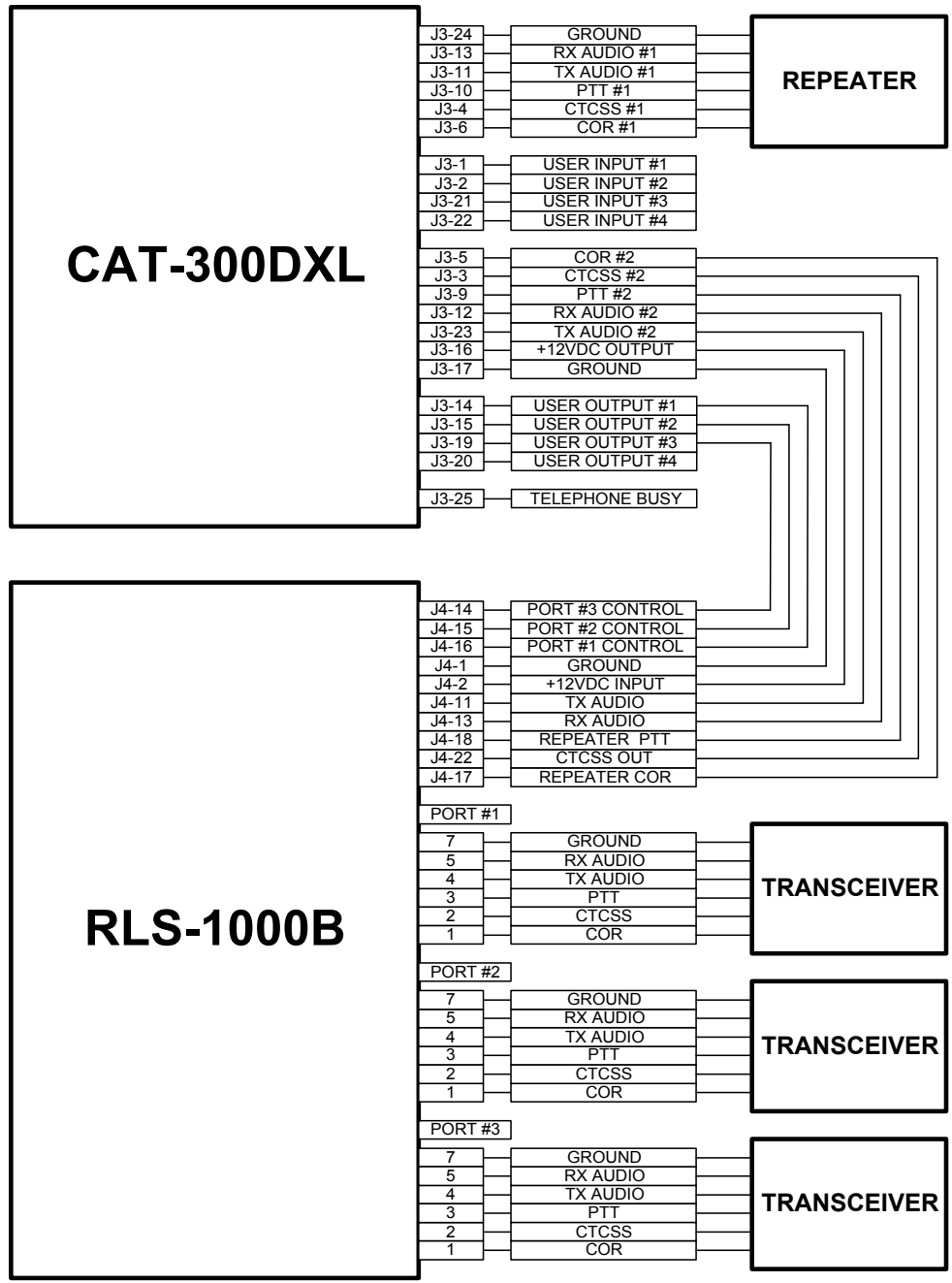

Figure 4

CAT-300/CAT-300DX - RLS-1000B Interconnect

The RLS-1000B provides a method to connect a repeater and two transceivers to the CAT-300 repeater controller. On the RLS-1000B set dipswitch #8 to ON. Transceiver selection is accomplished by grounding two of the control lines. To select a transceiver, enable the CAT-300 user function switch outputs connected to the control line inputs of the RLS-1000B. On the CAT-300, enable Zone 6 channel 1 to convert output #3 to a transceiver PTT and input #1 to a transceiver COR.

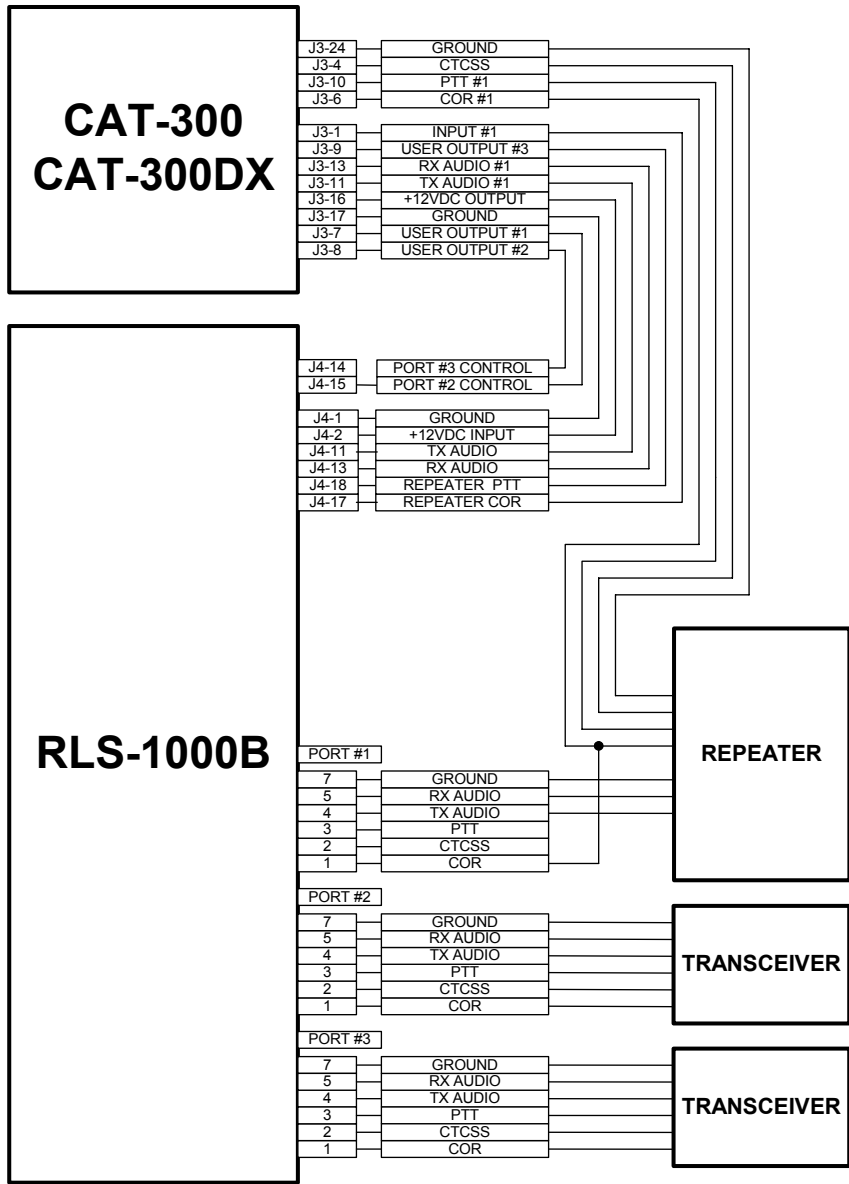

Figure 5

CAT-700 - RLS-1000B Interconnect

Figure 6 describes how to connect three remote base transceivers to the link port of the CAT-700B controller. Use the CAT-700B user function switches one, two and three to control the RBS-1000B Remote Base Switch.

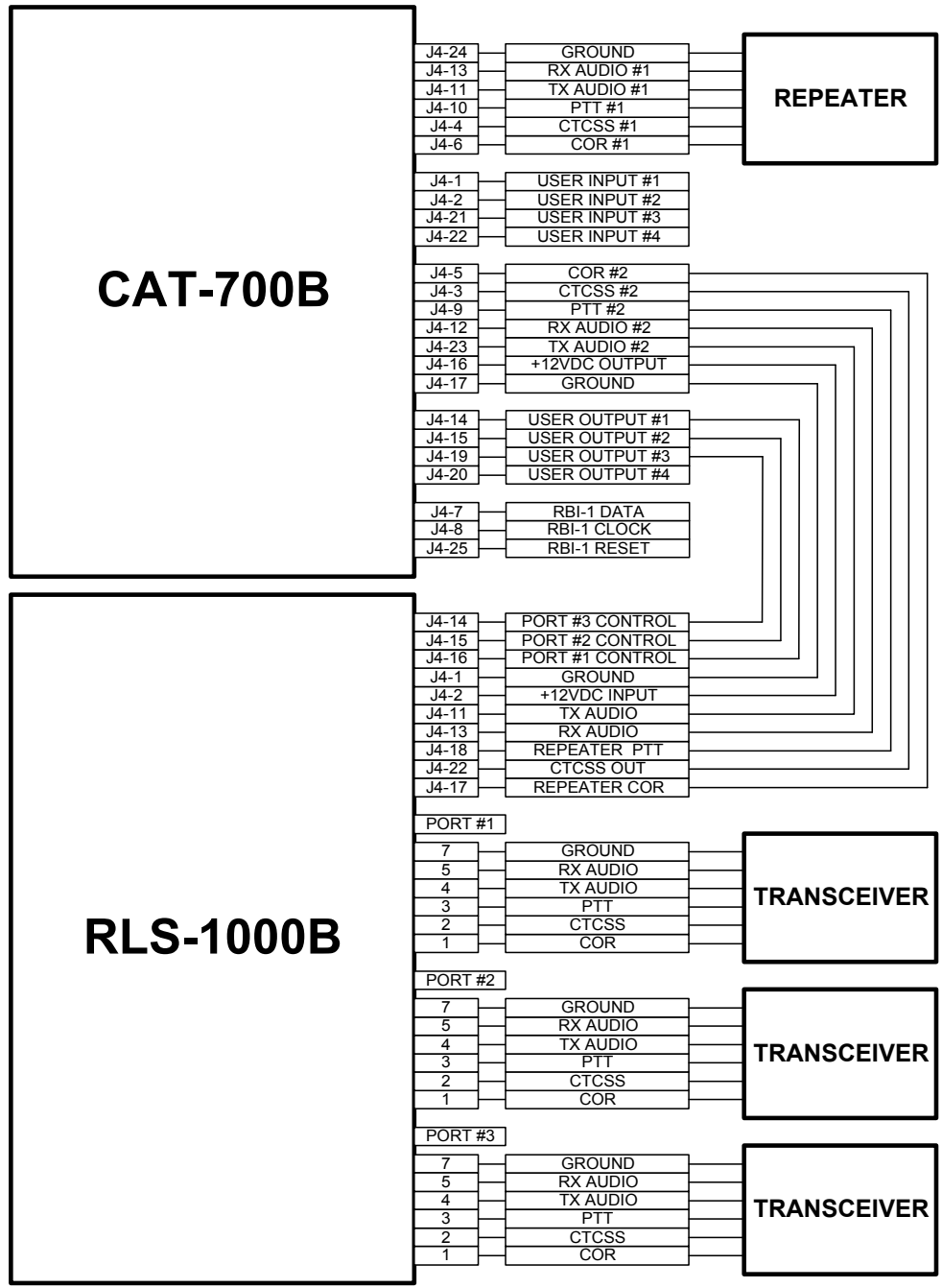

Figure 6

Parts List

8	Capacitor	10uF 16V	C3,C4,C5,C6,C9,C13,C17,C18
7	Capacitor	0.1uF 50V	C1,C7,C8,C10,C12,C14,C15
3	Capacitor	.0047uF 50V	C2,C11,C16 (Select Part)
3	Connector	DB-9F	J1,J2,J3
1	Connector	DB-25F	J4
1	Crystal	12MHz	Y1
3	Diode	1N4148	CR1,CR2,CR3
1	Header	1X3	J5
1	I.C.	LM340T-5	U4
1	I.C.	ICL7660	U3
1	I.C.	AT89C5124JC	U6
1	I.C.	TD62084AP	U10
1	I.C.	TPIC6C595	U9
1	I.C.	DS1232	U5
2	I.C.	LM348	U1,U7
2	I.C.	MAX335CNG	U2,U8
1	Jumper		JP1
3	Resistor	10K Variable	R1,R13,R25
3	Resistor	5K Variable	R7,R17,R29
1	Resistor	10K 10Pin SIP	R12
4	Resistor	10K 6Pin SIP	R8,R9,R20,R21
1	Resistor	4.7K 10Pin SIP	R24
1	Resistor	680 6Pin SIP	R31
2	Resistor	100 .25W	R4,R5
4	Resistor	620 .25W	R6,R16,R28,R30
3	Resistor	2200 .25W	R33,R34,R35 (Select Part)
9	Resistor	10K .25W	R2,R10,R11,R14,R18,R22,R23,R26,R36
4	Resistor	33K .25W	R3,R15,R19,R27
1	Switch	Dip 8 Position	SW1
6	Test Point		TP1,TP2,TP3,TP4,TP5,TP6

Drawing

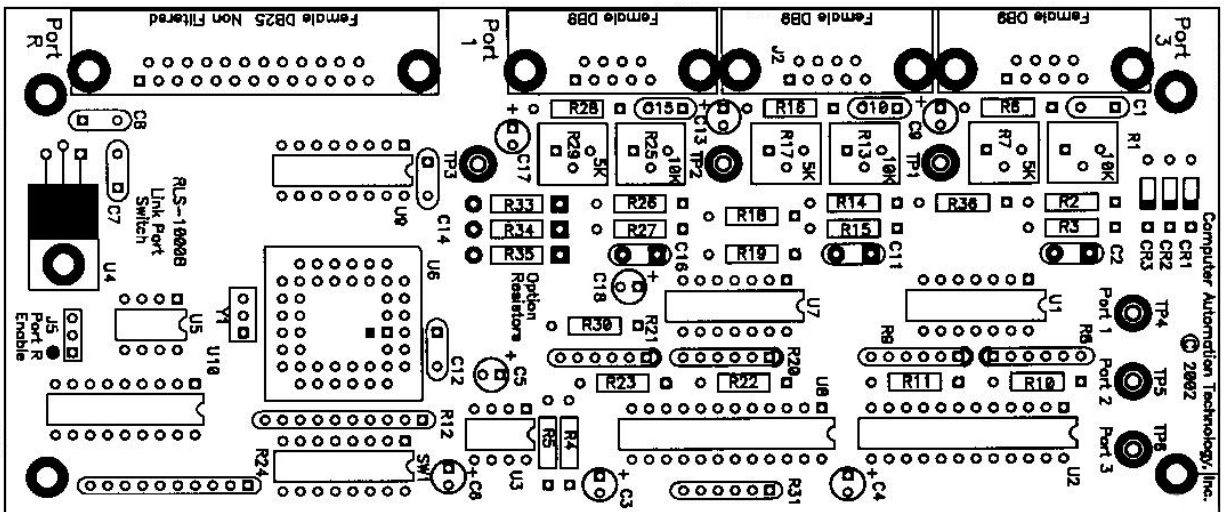
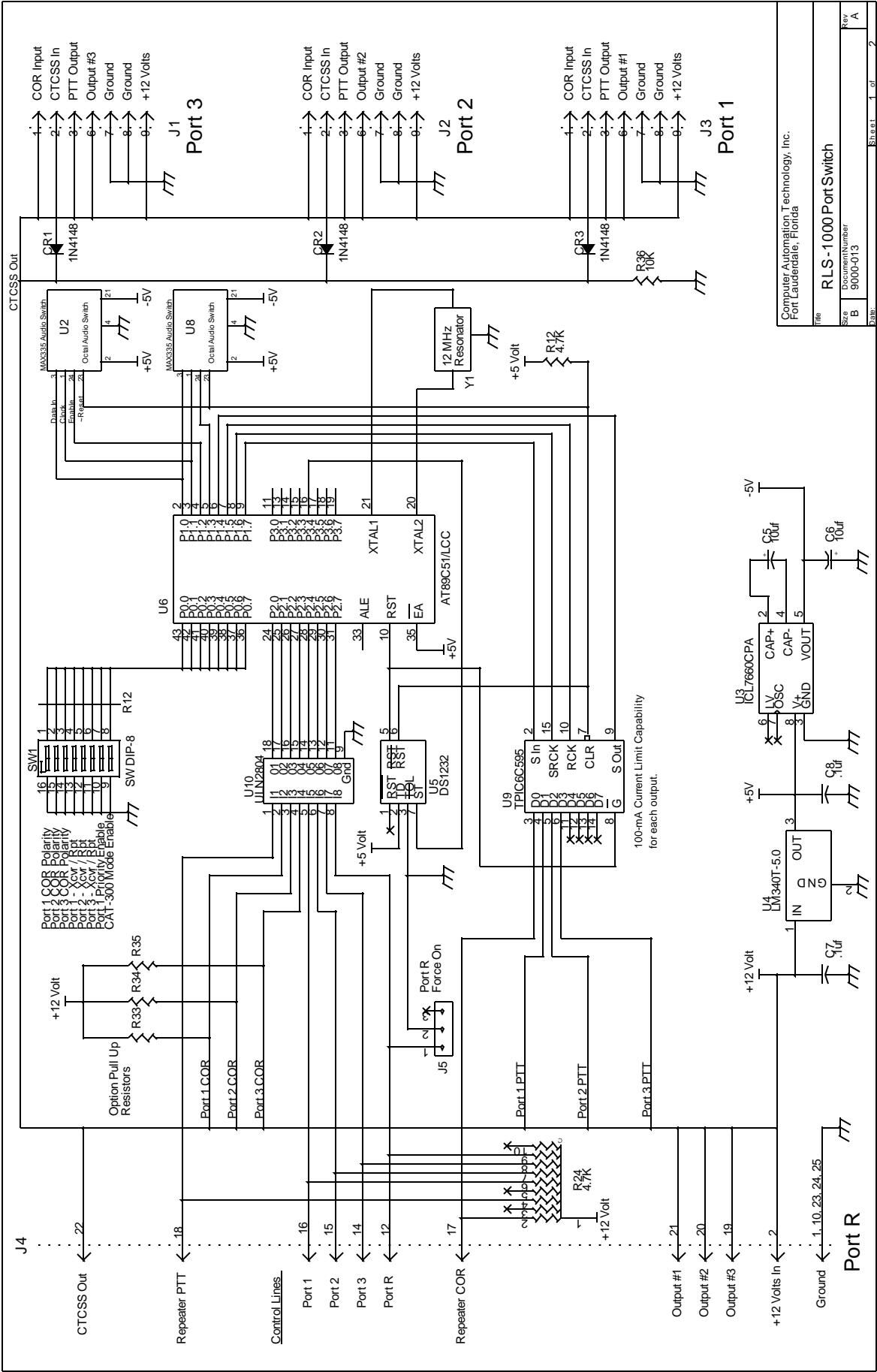

Figure 5



Computer Automation Technology, Inc.
Fort Lauderdale, Florida

Part # RLS-1000 Port Switch

Rev A

Sheet 1 of 2

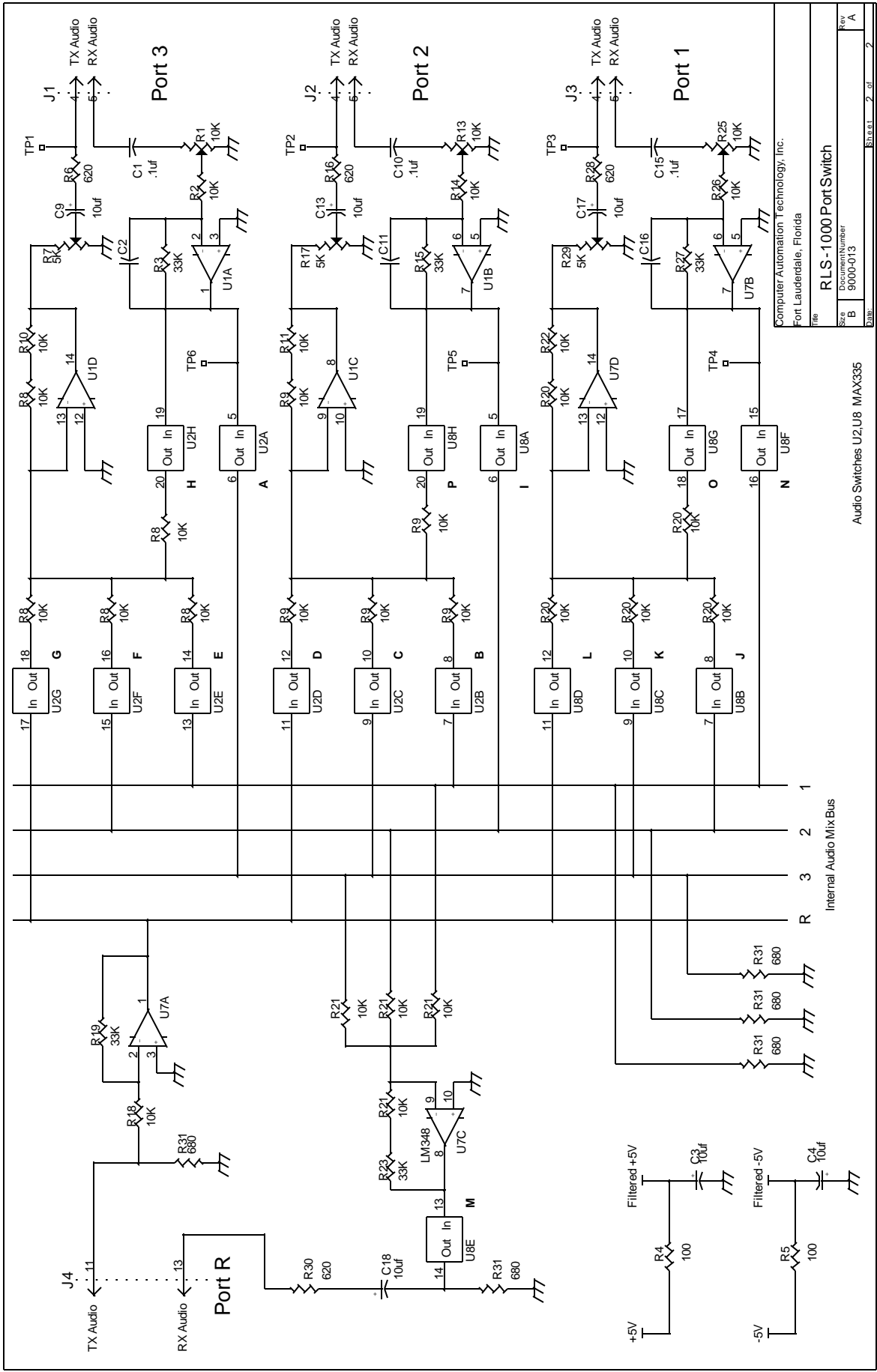

Computer Automation Technology, Inc.
 Fort Lauderdale, Florida
 File: RLS-1000 Port Switch
 Size: B
 Document Number: 9000-013
 Date: Sheet 2 of 2

Audio Switches U2,U8 MAX335